

Gh~~o~~stbusters Inspired Proton Pack Lighting

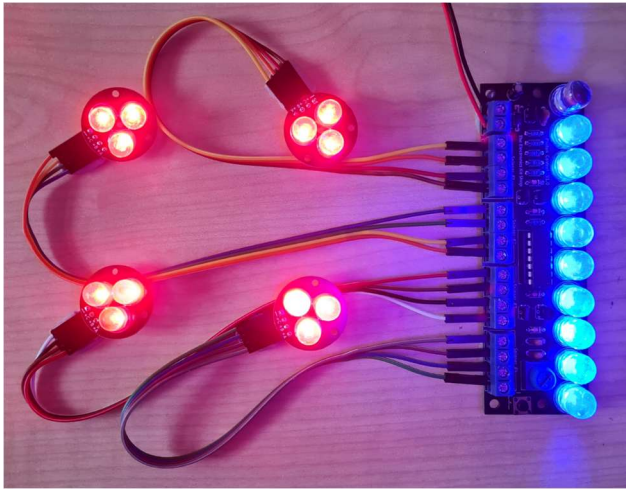

You'll be super proud to have these amazing lights in your Ghostbusters themed cosplay!

Designed in and made the UK, this fabulous electronic lighting comes with ready assembled Main Controller PCB for the Proton Charge Lights and four circular PCBs for the Cyclotron Lights, and has a preprogrammed real microcontroller containing the Proton Pack Lights software.

On the rectangular Main Controller PCB are ten bright blue massive 10mm diameter LEDs which progress upwards and show the Power Cell charging lights. The LEDs may be mounted on the front, or back, or side of the PCB to best suit your backpack project. The Mode pushbutton lets you select in which direction the LEDs will "fill-up", so you can mount the PCB either way up in your backpack.

Each of the four circular Cyclotron Lights PCBs has three large 8mm diameter red LEDs which can either be lit like light bulbs or optionally show a spinning effect, and each Cyclotron Light PCB illuminates in turn as the Power Cell cycles.

Your project comes with wires for each of the Cyclotron Lights and the Main Control PCB has screw terminal wiring connections so there's no need for soldering these to wire up your backpack. Your project is powered from a 9V PP3 battery (not included).

This really is a remarkable authentic looking project.

Electronics, PCBs and software all designed in Britain by *The Electronics Kit Shop*.



The Electronics Kit Shop



 <https://www.electronicsshop.com>

 info@electronicsshop.com



Visit Site

General Project Information

	CHOKING HAZARD Contains small parts, not suitable for small children. If children might use the finished project they must be supervised at all times.
	Persons with Photosensitivity Contains flashing bright lights

Required Skills

The project requires the basic ability to understand mechanical diagrams and follow assembly instructions.

Assembly of the project must be carried out by a competent adult or person under adult supervision.

Intended Use

The project is for educational or home domestic hobby environments for fun and amusement. The project is **not** for use in or near industrial, safety-related, medical devices, automotive or aviation.

Environmental

The finished project is intended for a clean, dry environment. Don't expose the project to direct sunlight and sources of ultraviolet light (UV).

	The project and associated waste must be disposed of in an environmentally friendly manner at a designated facility, and not be disposed of in household waste.
--	---

Power Supply

The project is intended to be supplied from a 9V PP3 alkaline battery. ***Under no circumstances exceed 16V.*** Excessive voltage or unstable supplies can damage components or pose a heat or combustion hazard.

Working Practices

Do not work on the project when it is connected to a power source.

Follow the instructions for wiring up the project.

Do not use bleaches, harsh cleaning agents, or solvents on your project or immerse your project in fluids.

This project contains bright LEDs; avoid looking directly into the LEDs when illuminated.

Ensure nothing conductive can touch the components or PCBs while the project is in use.

Immediately disconnect the project from the power source if there are any signs of heat, odours, smoke, or discoloration of components or the PCBs.

Project Dimensions and Features

Control PCB

Dimensions

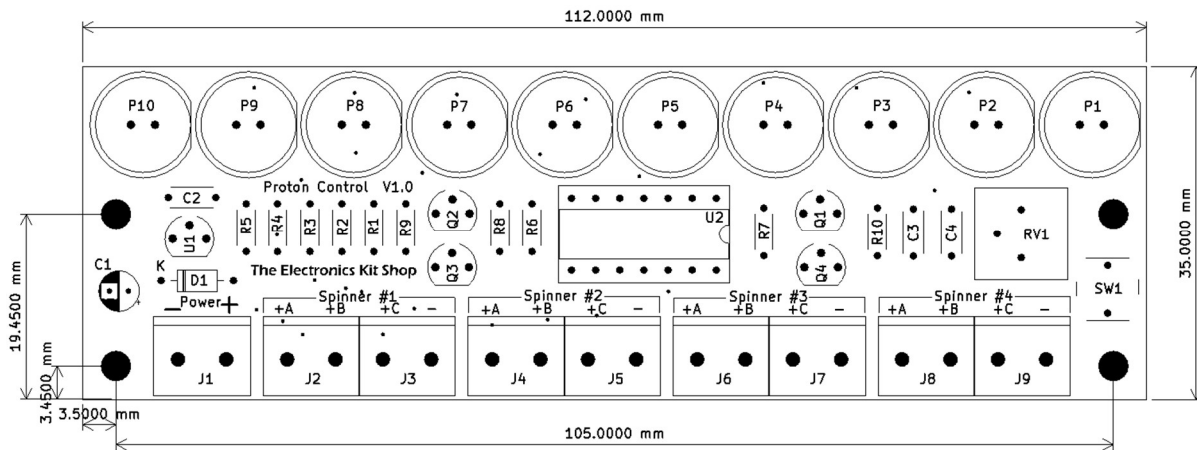

The four mounting holes are 3.2mm diameter (suits M3 screws).

Component Mounting Options

Component	Front of PCB	Back of PCB	To the Side	Flying Leads
Mode Pushbutton SW1	✓	✓	✗	✗
Speed Control RV1	✓	✓	✗	✗
Screw Terminal Blocks J1 thru J9	✓	✓	✗	✓
Blue LEDs P1 thru P10	✓	✓	✓	✓

The Mode Pushbutton, Speed Control, and Screw Terminal Blocks may be fitted on either side of the PCB, or the Screw Terminal Blocks may be omitted so the wires are soldered directly to the PCB.

Your Control PCB may have the blue LEDs fitted on either side of the PCB, or fitted at 90 degrees so they face outwards to the side of the PCB. The blue LEDs are approx. 14mm tall.

Note: The Mode Pushbutton allows you to choose in which direction the LEDs “fill up”, so you can mount the Control PCB either way up.

Constructed Views

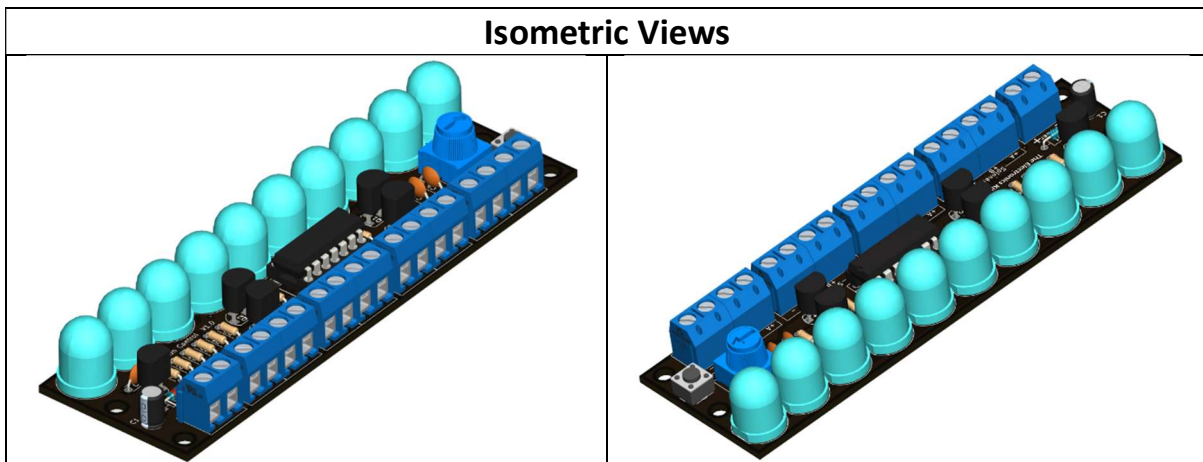
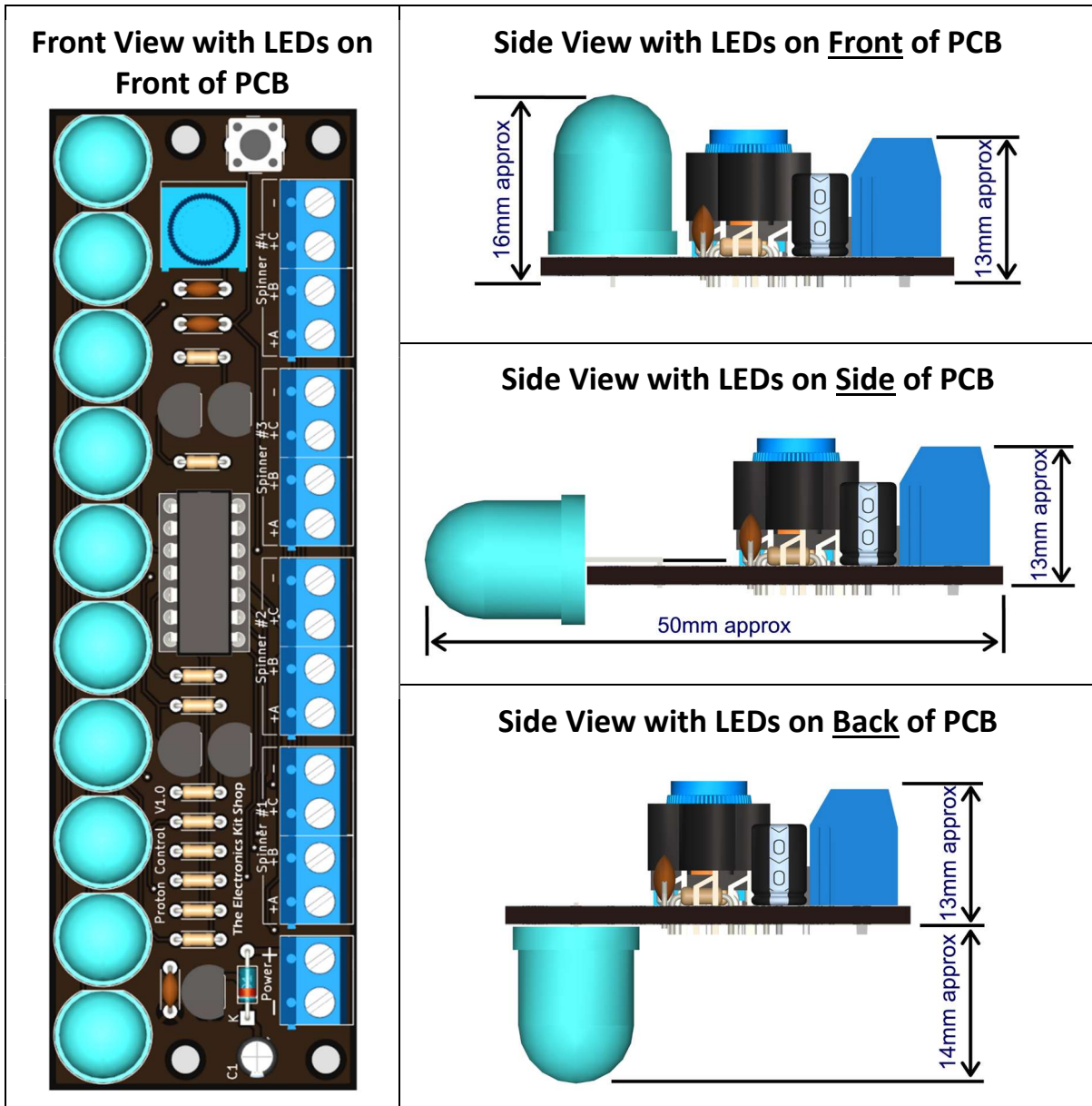

Cyclotron PCB

Dimensions

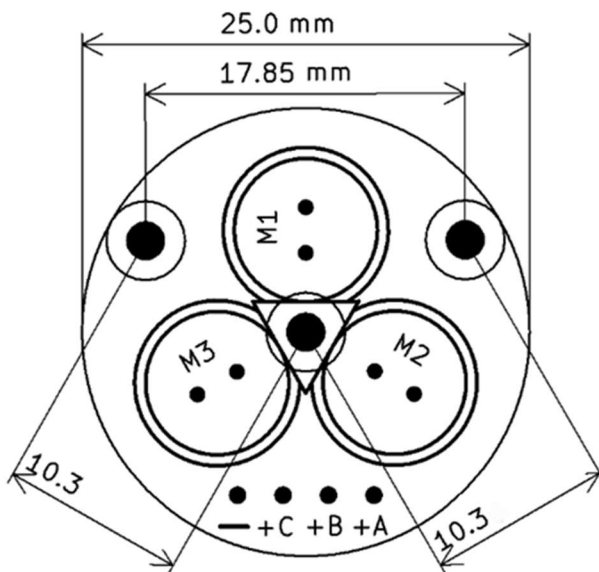

There are 4 Cyclotron PCBs in your project which each have 3 red LEDs. When they are activated, these have a “spinning” effect or they can be lit like normal light bulbs instead

The two mounting holes on the outside are 2.2mm diameter (suits M2 screws).

The centre 2.2mm diameter hole can be used if you want, but note that it is too close to the LEDs to fit a standard M2 screw head.

The 3 LEDs are mounted on the front of the PCB, and the wiring connectors onto the back of the PCB.

Component Mounting Options

Component	Front of PCB	Back of PCB	To the Outside	To the Inside
Straight wiring connector	✗	✓	✗	✗
90 degrees angled wiring connector	✗	✓	✓	✓
Directly soldered wires	✓	✓	✓	✓
Red LEDs M1 thru M3	✓	✗	✗	✗

Your Cyclotrons may have a straight wiring connector, or a 90 degrees angled wiring connector, or have the connectors omitted for soldering the wires directly through the PCB holes instead.

The red LEDs always stand upright on the front of the PCB.

Constructed Views

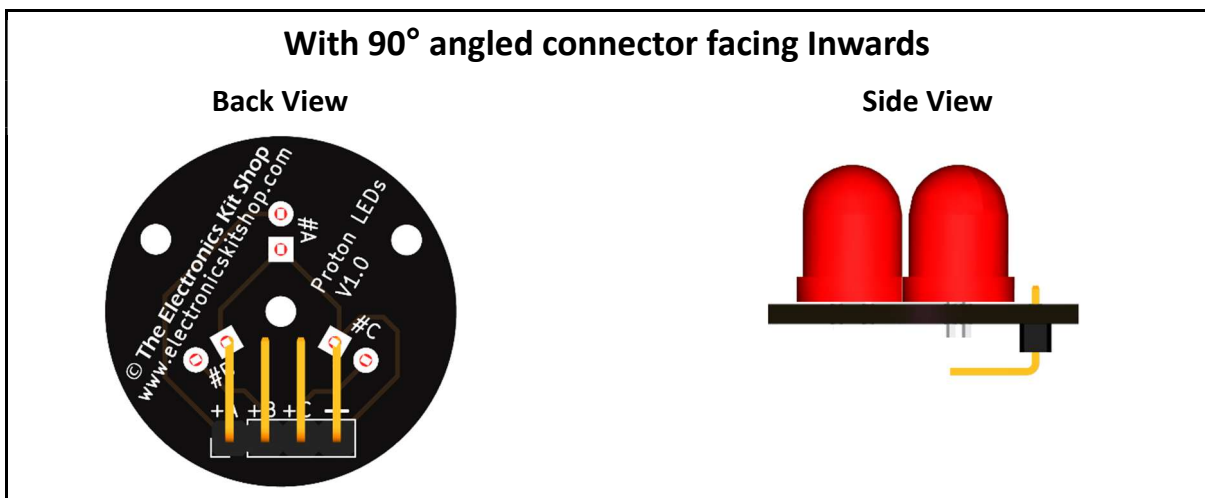
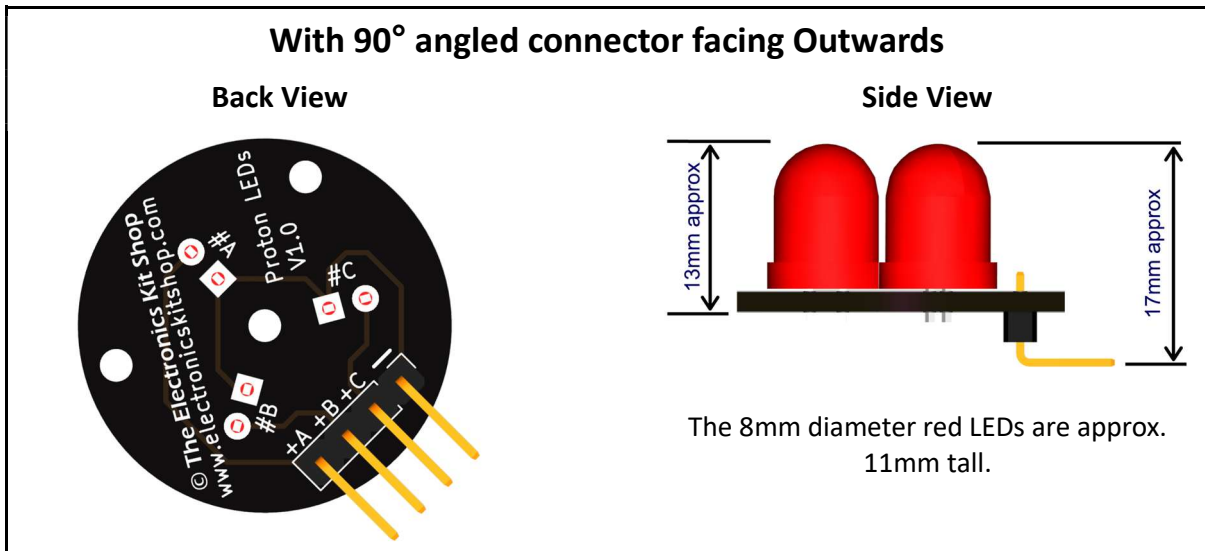
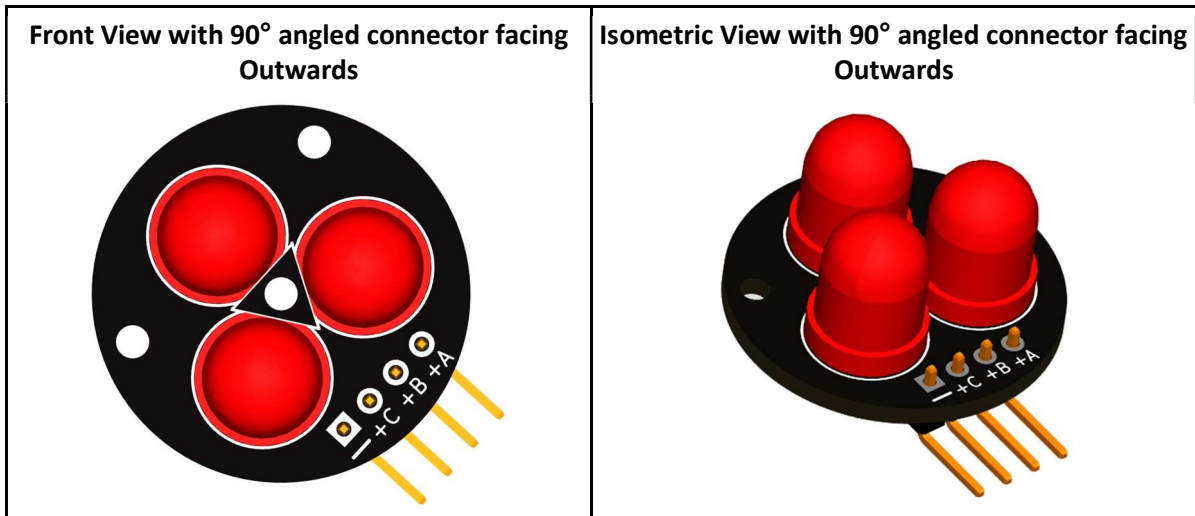

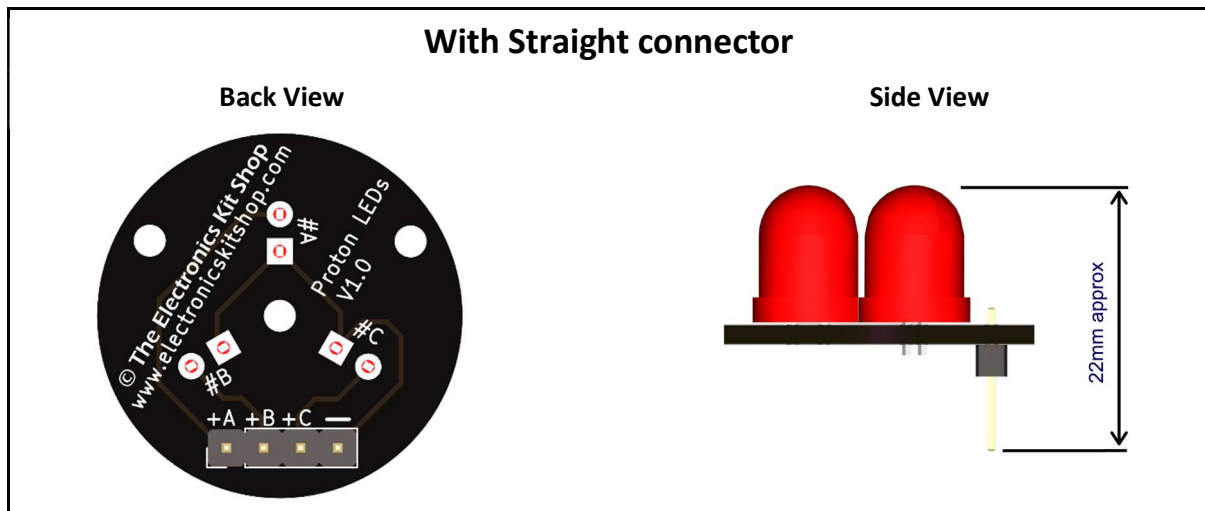

General Mounting of all the PCBs

Use the PCB mounting holes wherever possible. Adhesives such as glue could be used but be very careful of making contact with the electronic components, and make sure there is some free airflow around them.

Ensure nothing conductive can touch the components or PCBs while the project is in use.

Wiring up your Project

Wiring the Cyclotron Spinners

Every Cyclotron Spinner is wired with four direct wires.

For each Cyclotron Spinner, on the Control PCB and on the Cyclotron PCBs are printed:

- +A
- +B
- +C
- - (a minus sign)

The Control PCB **+A** is wired directly to the Cyclotron PCB **+A** and so on.

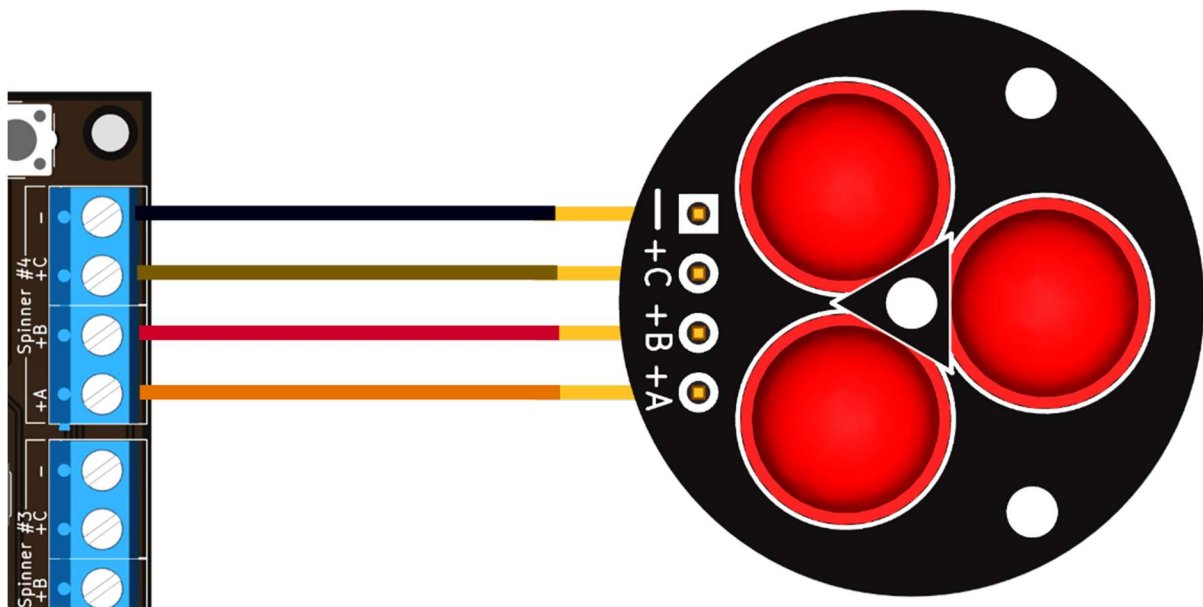

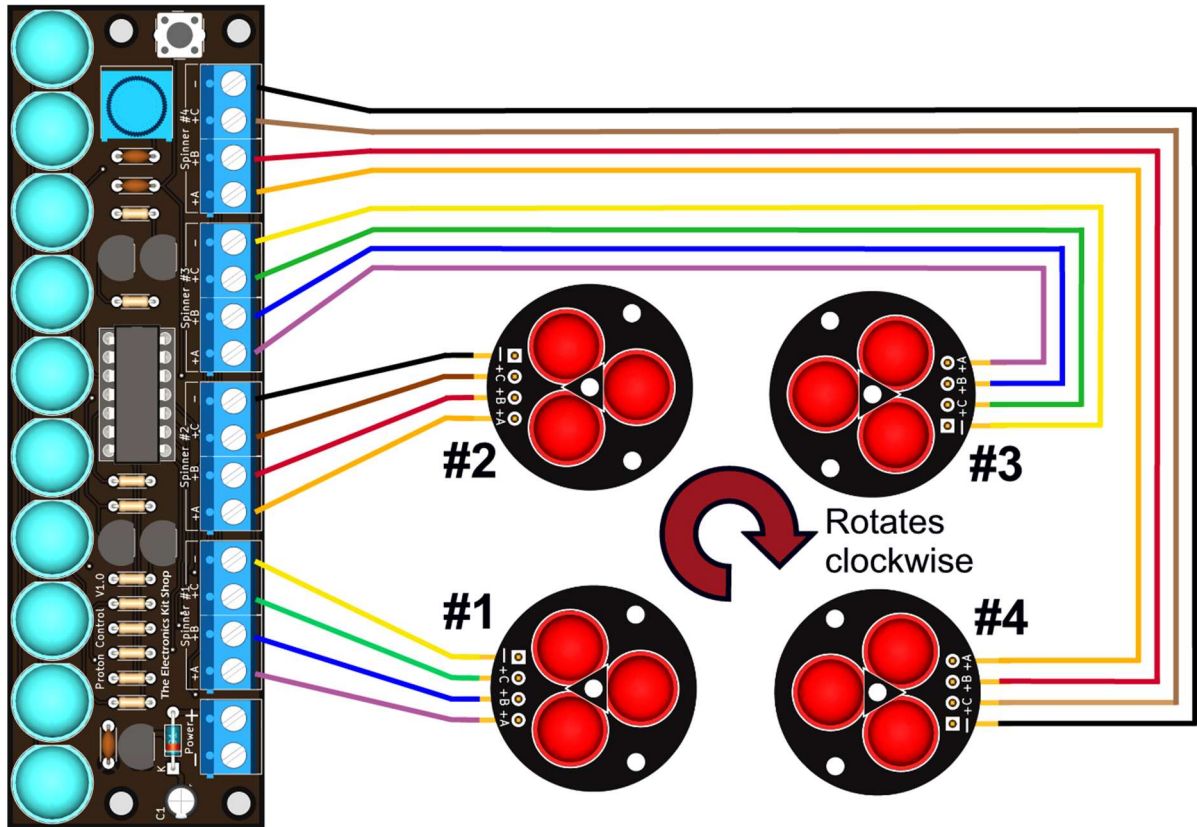

The colours of the wires are not important. Your project might contain many different colours of wires and this will help you to identify where all the different wires in your backpack are going. The important thing is that they go to the right places.

The Cyclotron Spinners illuminate in turn from #1 thru #4 in a clockwise direction.

You can use the Mode pushbutton if you want to mount your Control PCB the other way up and have the blue LEDs still filling from bottom to top. The Cyclotron Spinners will always go in the same direction from #1 thru #4.

Wiring the Battery Supply

Wire your Control PCB to the battery connector via a switch, in-line with the '+' terminal.

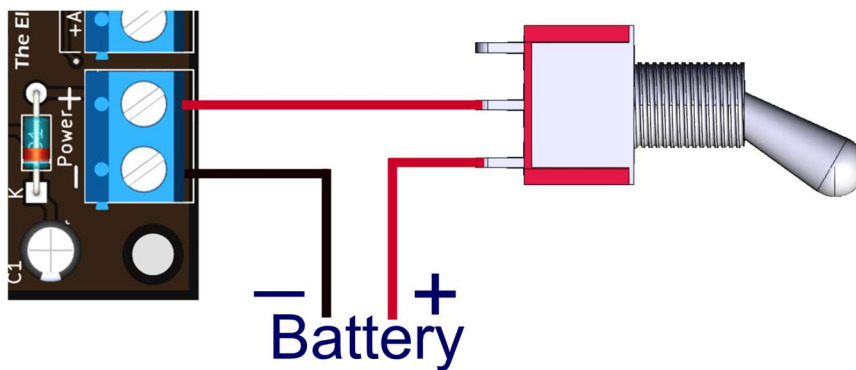

Using your Project

Mode Pushbutton

When you press this button, the next operating Mode is selected. When you have pressed the button to reach the end of the available Modes, it goes back to the first Mode again.

Your project has several **Modes**:

1. Power Cell LEDs cycling from **Bottom to Top** with spinning Cyclotrons
2. Power Cell LEDs cycling from **Top to Bottom** with spinning Cyclotrons
3. Power Cell LEDs cycling from **Bottom to Top** with statically lit (light bulb) Cyclotrons
4. Power Cell LEDs cycling from **Top to Bottom** with statically lit (light bulb) Cyclotrons
5. Power Cell LEDs cycling from **Bottom to Top** with fading light bulb Cyclotrons
6. Power Cell LEDs cycling from **Top to Bottom** with fading light bulb Cyclotrons
7. **Test Mode** - all LEDs lighting up one after another to test them

In your Proton backpack you would only use one of the six cycling modes, and which one you use depends upon which way up you will be mounting the Control PCB and how you would like the Cyclotrons to be shown.

Your project has a built-in Test Mode: press the Mode pushbutton until the blue Power Cell LEDs are lighting up just one at a time, and the Cyclotron Spinner LEDs also light up just one at a time. This lets you check that every LED is separately working. Press the Mode pushbutton again to exit the Test Mode and go to one of the normal cycling operating modes.

The microcontroller remembers which Mode you selected so it always starts in that Mode when you next switch on.

Speed Control

You can turn the Speed Control knob to set the speed of the LED animation to be whatever is best for your project.

In the Ghostbusters movies the Power Cell cycles from bottom to top about once per second.

General Usage

Please note that this project:

- Contains **flashing lights**
- **Is not suitable for small children due to small parts**
- Has bright LEDs; don't stare directly into them
- Must be used only for the purposes of fun and amusement
- Is for occasional UK hobby use and must not be used near sensitive electronic or medical equipment
- Must be protected from extremes of temperature, rain and moisture

- Is inspired by the Ghostbusters movie props and is in no way connected with those movies or their producers

If the LEDs on the project begin to dim, or the project begins to malfunction or no longer comes on at all when you connect power, it is likely the battery needs to be replaced.

And for the environment - always dispose of electrical waste in the proper facilities.

You Might Also Like....



Document Version 1.02

The Electronics Kit Shop

Warwickshire UK

© 2025

<https://www.electronicsshop.com>

info@electronicsshop.com

<https://www.ebay.co.uk/usr/electronics-kits>

<https://electronicsshop.etsy.com/>